

# INDOOR UNIT

RSUB-57-L

## CODE OPTIONS

**CSD-1** Manual Reset LWCO

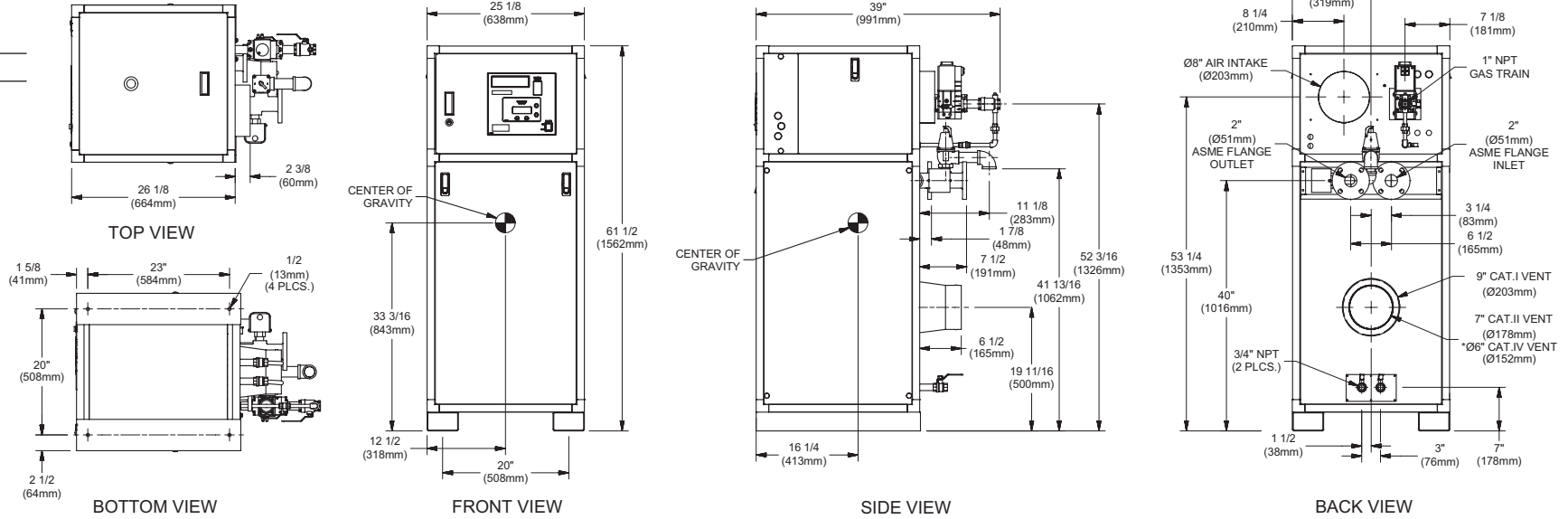

**Notes:**

1. Dimensions are approximate and should not be used to "rough-in" equipment.
2. Dimensions are subject to change without notice.

## BOILER CERTIFIED RATINGS & CAPACITIES

<b>Fuel Type</b>	Natural/Propane Gas	<b>Boiler FLA</b>	8.2*
<b>Input BTU/hr.</b>	1,000,000 / 293 kW	<b>Min. Gas Pressure Required</b>	2" W.C.**
<b>Output BTU/hr.</b>	853,000 / 250 kW	<b>Max. Gas Pressure Allowed</b>	14" W.C.
<b>Electrical Requirements</b>	(L1, NEU, GND) 120 VAC / 1 ph / 60 hz	<b>Operating Weight</b>	623 lbs. / 283 kg.

## BOILER TEMPERATURE RISE / PRESSURE DROP

20°F / 11.1°C				25°F / 13.9°C				30°F / 16.7°C				35°F / 19.4°C			
Flow Rate		Pressure Drop		Flow Rate		Pressure Drop		Flow Rate		Pressure Drop		Flow Rate		Pressure Drop	
GPM	L/s	Ft	kPa	GPM	L/s	Ft	kPa	GPM	L/s	Ft	kPa	GPM	L/s	Ft	kPa
85.3	5.4	3.46	10.2	68.2	4.3	2.29	6.7	56.9	3.6	1.63	4.8	48.7	3.1	1.23	3.6

## BOILER / WATER HEATER TRIM & CONTROLS

<b>Main Gas Valve</b>	Dungs MBC-SE	<b>Air Switch</b>	Cleveland NS2
<b>Firing Valve</b>	1"	<b>Blower Motor</b>	Fasco 1/2 hp - FLA 2.3
<b>Ignition Control</b>	Honeywell RM7895C	<b>Relief Valve - MW</b>	3/4" x 3/4" set @ 125 psi
<b>Operating Control</b>	HeatNet®	<b>Relief Valve - MB</b>	3/4" x 3/4" set @ 50 psi
<b>High Limit</b>	Jumo	<b>Flow Switch</b>	TACO
<b>Main Ball Valve</b>	1"	<b>Pilot Regulator</b>	White-Rodgers 25M

## WATER HEATER HOURLY RECOVERY CAPACITY (GPH & LPH)

40°F	22°C	60°F	33°C	80°F	44°C	100°F	56°C	120°F	67°C	140°F	78°C
2491	9416	1661	6277	1245	4708	996	3766	830	3139	712	2690

## A.S.M.E.

<b>ASME Sect IV Htg Surface</b>	126.07 Sq. Ft. / 11.71 Sq. M.	<b>Design Data</b>	Max. 160 psig & 250°F
<b>Water Volume</b>	4 gal / 15.14 Liters		

\* Add circulator amps.

\*\* For incoming gas pressures lower than 2" W.C. natural or propane, consult factory.

REP FIRM \_\_\_\_\_  
 SUBMITTED BY \_\_\_\_\_  
 JOB NAME \_\_\_\_\_  
 ARCHITECT \_\_\_\_\_  
 ENGINEER \_\_\_\_\_  
 CONTRACTOR \_\_\_\_\_  
 DATE \_\_\_\_\_

# FUTERA III 1000

**Category I, II or IV Appliance**  
 (see Installation and Operation Manual for venting information)



A Division of Mestek, Inc.  
 Westfield, MA 01085  
 (413) 568-9571

# OUTDOOR UNIT

RSUB-112-B

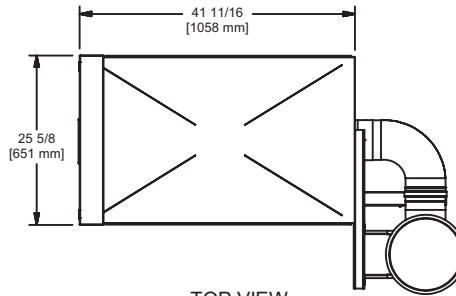

TOP VIEW

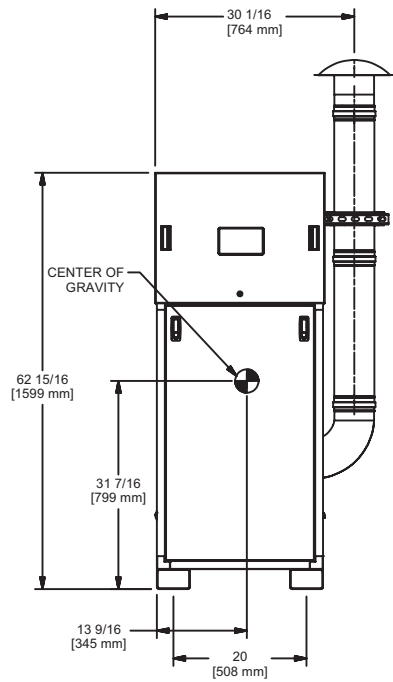

FRONT VIEW

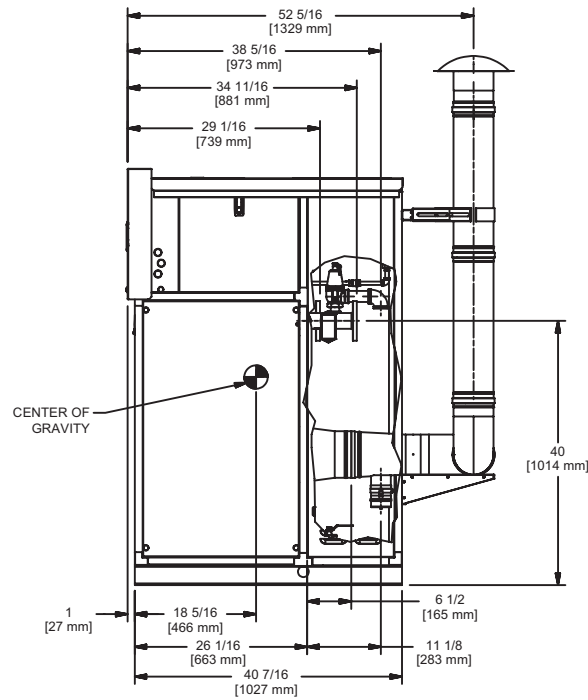

SIDE VIEW

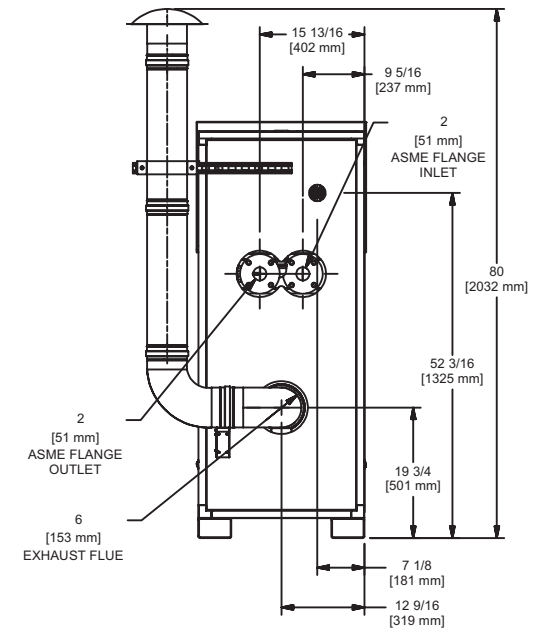

BACK VIEW

**FUTERA III 1000**

**Notes:**

- 1. Dimensions are approximate and should not be used to "rough-in" equipment.
- 2. Dimensions are subject to change without notice.